

### SIMPLE, EASY AND SAFE PULLING JOB

Equipped with fast-acting Jaws, Powerram's unique patented Easy Pullers are dedicated for the absolute user-friendly and safe dismantling job in the market today. The most simple and efficient design - fast acting Jaws bring the users to position the puller on the part quickly and correctly by one man operating as well.

### USER-CONVENIENTLY:

- Absolutely user-conveniently raised from fast-acting and self-positioning jaws, locking on the part with just one man operating only.
- 360° Rotary Handle socket enables the user to operate the pumping in all directions.
- Spring loaded live centring nut for easily positioning without missing ( removable ).
- Optional hydraulic force are available from 4 Ton to 30 Ton versions.
- The patented Two stages stroking design on 20 & 30 Ton versions offers quickly connecting to the object and high hydraulic force for pulling to save much pumping time and efforts.
- Attached extension rods allow the user to extend the stroke according to the needs.
- User-Friendly package with the well assembled puller inside for immediately operating and easily repackaging after objects pulled out.

### TECHNICAL DATA

Capacity	Model No.	Reach (Max. mm)	Spread (Max. mm)	Stroke (mm)				Jaw Tip (mm)			Weight (kg)
				H	E	F	G	A	B	C	
4 Ton	PME400	190	315	60	42	22	40	13	10	22	8.0
6 Ton	PME600	230	390	70	45	23	50	13	10	22	9.8
8 Ton	PME800	280	460	85	50	25	70	13	13	27.5	11.7
12 Ton	PME1200	300	515	85	60	28	70	15	16.5	29	14.8
20 Ton	PME2000	325	520	111	80	40	62	20	27	33	25.7
30 Ton	PME3000	415	620	111	98	50	85	20	27	38	36.0

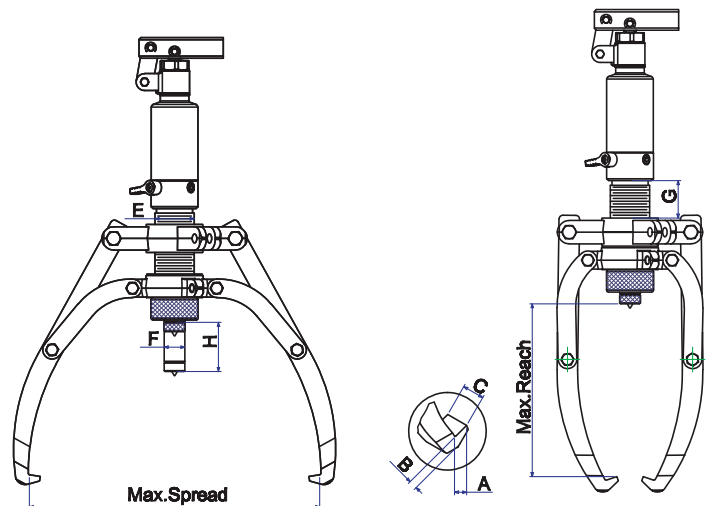

### SAFE:

- The self-contained Hydraulic pump equipped with the built-in safety valve is designed to prevent the overload to the puller.
- The built-in safety valve cannot be rebuilt by user in any ways to prevent any injury and damage to the user and/or the puller.
- Self-locking jaws eliminate the puller jaw slipping off under loading and/or hydraulic force releasing.

### COST SAVING:

- The built-in safety valve keeps away from the overloading always to ensure all spare parts working normally.
- Self-positioning & centring prevent the damage to the shaft as well.
- Service life of puller is prolonged by the built-in safety valve.
- Impact packaging conveniently positioning, efficiently pulling cause much save on manpower and operating time.
- The first 2 / 3 way Hydraulic Easy Puller brings the users the best option for much cost saving.